

Transverse Conveyors

Section 9 – Transverse Conveyors

原装进口力士乐皮带
代理商电话 18823303057

BS2/... Transverse conveyors are designed to transfer pallets for short transport distances (e.g. between two rectangular lines) or as cycle-independent workstations. The BS2, BS2/M, and BS2/K are powered units that use standard or antistatic toothed belts for pallet transport. The BS2/O is a non-powered toothed belt unit designed to be driven

by a standard BS2 using a special drive coupling, thus saving the cost of a gearbox and motor. Unless otherwise stated, transverse conveyors are reversible.

Flat-top chain and roller chain BS2 units are available in standard and heavy duty configurations and provide increased payload carrying capacity.

Specify conveyor width, length, conveyor speed, motor voltage/frequency, motor position, and motor orientation when ordering.

The LG2 lift gate kit provides personnel and vehicle access through a conveyor line and uses a standard BS2 unit.

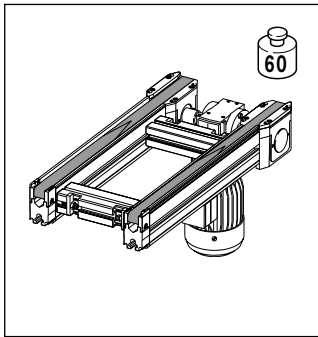

BS2
Transverse Conveyors
9-2 to 9-3

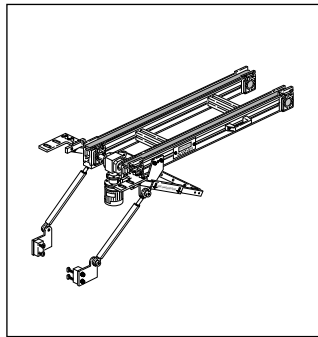

LG2
Lift Gates
9-4 to 9-5

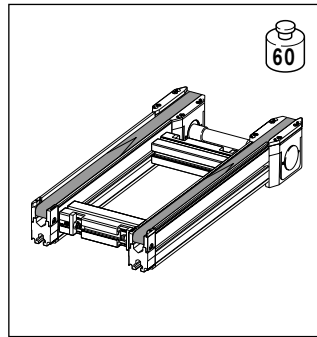

BS2/O
Transverse Conveyors
9-6 to 9-7

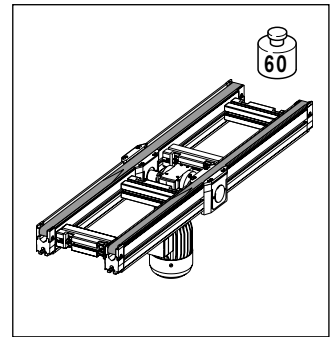

BS2/M
Transverse Conveyors
BS2/M 9-8 to 9-9

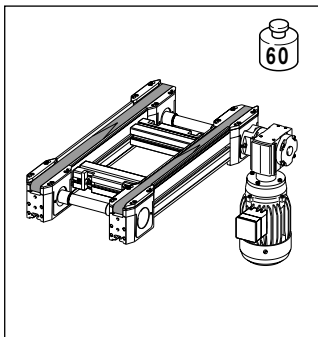

BS2/K
Transverse Conveyors
9-10 to 9-11

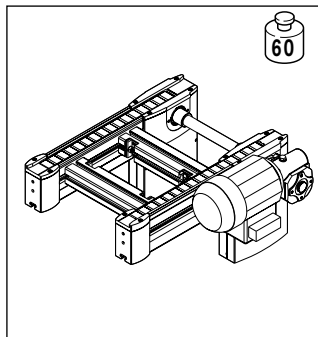

BS2/C Flat-top Chain
Transverse Conveyors
9-12 to 9-13

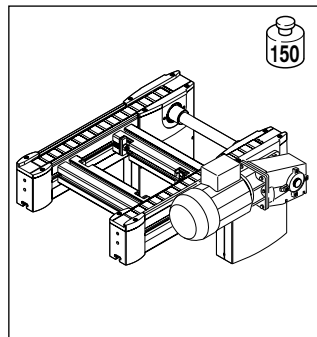

BS2/C-H H.D. Flat-top Chain
Transverse Conveyors
9-14 to 9-15

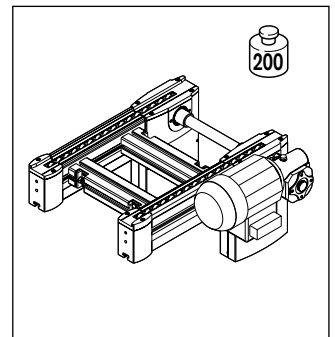

BS2/R Roller Chain
Transverse Conveyors
9-16 to 9-17

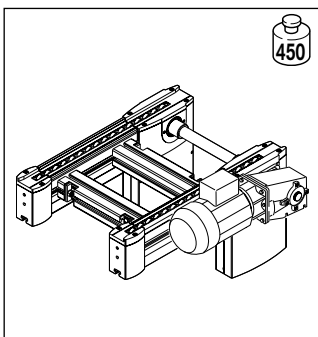

BS2/R-H H. D. Roller Chain
Transverse Conveyors
9-18 to 9-19

Transverse Conveyors

Transverse Conveyor

Model BS2

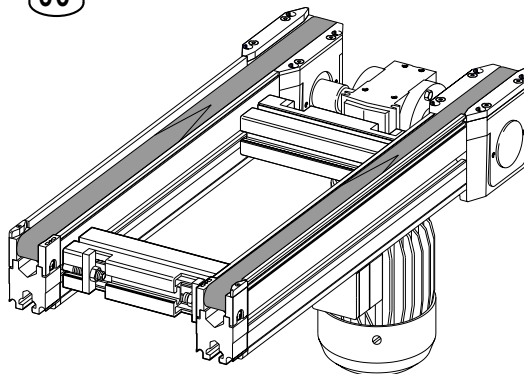

Transverse conveyors are most often used to transfer workpiece pallets between parallel conveyor sections. They are also used to construct cycle-independent workstations, or small systems with short conveying lengths. The unit itself is modular and comes with its own mid-mounted or outboard mounted drive and pre-installed toothed belts.

Workpiece pallet movement can be reversed if desired. In normal operation, the maximum load capacity for transverse conveyors is 60 kg forward and 30 kg in reverse. In addition, positioning and control modules can be mounted on transverse conveyors.

Transverse conveyors are available in any length from 240 mm to 6000 mm in 5 mm increments. Specify conveyor width, length, conveyor speed, motor voltage/frequency, motor position, motor orientation and belt version when ordering.

Transverse conveyors come fully assembled and include all required mounting hardware. Motor voltage and frequency options are described in table 9-1.

NOTE: Transverse conveyor widths (B) in excess of 160 mm are available with either a mid-mounted or outboard mounted motor as shown.

Please contact our applications engineering department for non-standard length, width, speed, or voltage.

Outboard Mounted Motor Orientation

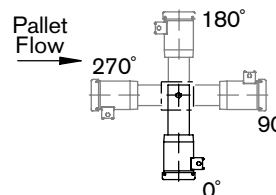

Motor Position

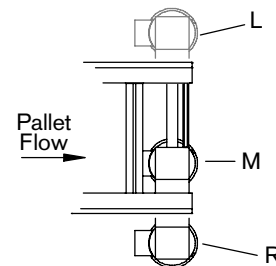

Ordering Information for Transverse Conveyor BS2

Specify part number, then select from the options below.	Your Choices are:	Part Number 3842 999 716
		Your selection:
Width (B) in mm	160, 240, 320, 400, 480, 640, 800, 1040	_____ mm
Motor Position	R, M*, L	_____
Motor Orientation (outboard mount only)	0°, 90°, 180°, 270°	_____
Belt Version	Non-Antistatic (N) Antistatic (A)	_____
Transverse Conveyor length (L)	240 mm to 6000 mm (in 5 mm increments)	_____ mm
Nominal Conveyor Speed (m/min)**	6, 9, 12, 15, 18**	_____ m/mm
Motor Voltage/Frequency	See Table 9-1	_____ V _____ Hz

* Mid-mounted motor not available in 160 mm wide transverse conveyors.

** Full load conveyor speeds vary depending on motor frequency. See table 9-1

Transverse Conveyors

Technical data for BS2

Nominal belt speed	= See Table 9-1
Load capacity forward	= 60 kg
Load capacity reverse	= 30 kg
Motor RPM @ 50 Hz	= 1400
Motor RPM @ 60 Hz	= 1700
Motor electrical specifications	= See Table 9-1

Electrical data for BS2

Nom. M/min	Actual Speed		HP		Full Load Amps @					
	50 Hz	60 Hz	50Hz	60Hz	208/60	240/60	380/50	415/50	480/60	575/60
6	6.1	7.4	.24	.28	1.6	1.3	0.86	0.72	0.67	0.55
9	9.1	8.9	.24	.28	1.6	1.3	0.86	0.72	0.67	0.55
12	12.2	11.1	.24	.28	1.6	1.3	0.86	0.72	0.67	0.55
15	15.2	14.8	.24	.28	1.6	1.3	0.86	0.72	0.67	0.55
18	18.3	18.5	.24	.28	1.6	1.3	0.86	0.72	0.67	0.55

Note: Electrical Data for reference only. Refer to motor name plate for actual amperage ratings.

Table 9-1

Dimensional data for BS2

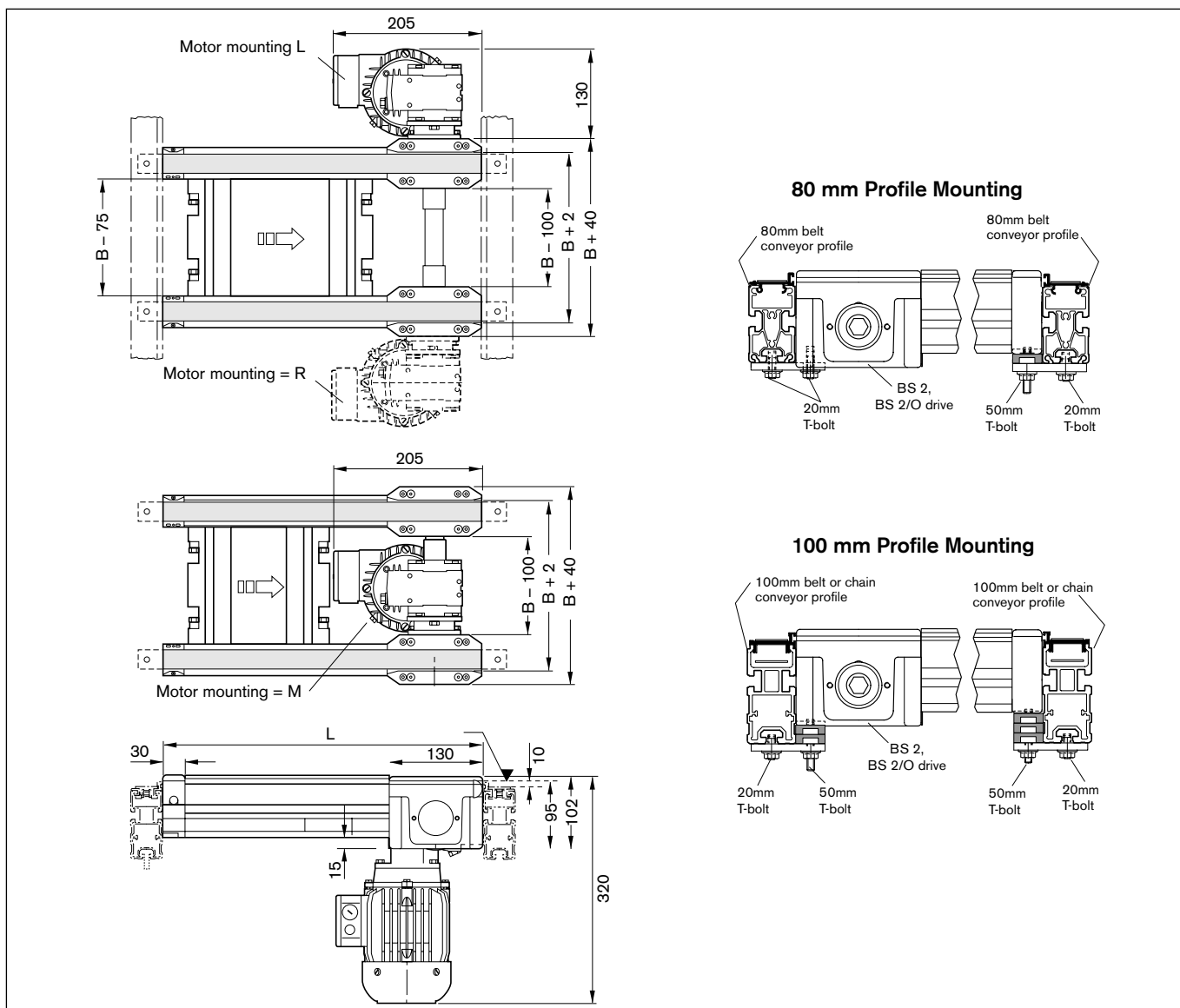

Transverse conveyor width (B_{WT}) must match pallet length (L_{WT}) or width (B_{WT}), depending on orientation.